

Manual Sound Bar - SB1

Installation Manual



Neets

Foreword

This document describes how to install and operate the Neets Sound Bar - SB1.

COPYRIGHT - All information contained in this manual is the intellectual property and copyrighted material of Neets. All rights are reserved. No third party is allowed access to content, information or data in this manual without Neets' express written consent.

CHANGES - Neets reserve the right to change the specification and functions of this product without prior notice.

Questions, AFTER reading this manual, can be addressed to the local distributor or:

Neets A/S
Langballe 4
8700 Horsens
Denmark

by E-Mail: Support@Neets.dk
or you may use our contact form at www.neets.dk

Revision list

This document has the following revision changes:

Author: Date	Description	Pages	Rev
DB: 01-11-2017	First release	All	1.00
DB: 13-11-2017	Edits in chart	12	2.00
DB: 22-11-2017	Edits to note	7	3.00
	Paragraph removed	11	
	Edits to graphics	12	
	Section about Audio input settings removed	16	

What is in the box?

The box contain the following items:

- 1 x Neets – Sound Bar SB1
- 1 x Neets 24V/2.5A external power supply
- 1 x Power cable for power supply
- 2 x Terminal connectors
- 2 x Wall brackets
- 4 x M5 screws for wall brackets
- 4 x Rawlplugs
- 4 x Rubber feets
- 1 x Velcro set

Important Safety Instructions

Caution:

Read these instructions.

Read and understand all safety and operating instructions before using the equipment.

Keep these Instructions.

The safety instructions should be kept for future reference.

Heed all warnings.

Follow all warnings and instructions marked on the equipment or in the user information.

Avoid attachments.

Do not use tools or attachments that are not recommended, as they may be hazardous.

Warning!:

- This equipment should be operated only from the included power supply.
- To remove power from the equipment safely, remove all power cords from the rear of the equipment, or the desktop power module (if detachable), or from the power source receptacle (wall plug).
- Power cords should be routed so that they are not likely to be stepped on or pinched by items placed upon or against them.
- Do not defeat the safety purpose of a polarized or grounding-type plug. A polarized plug has two blades with one wider than the other. A grounding-type plug has two blades and a third grounding prong. The wide blade or the third prong is provided for your safety. If the provided plug does not fit into your outlet, consult an electrician for replacement of the obsolete outlet.
- Unplug this apparatus during lightning storms or when unused for long periods of time.
- Refer all servicing to qualified service personnel. There are no user-serviceable parts inside. To prevent the risk of shock, do not attempt to service this equipment yourself because opening or removing covers may expose you to dangerous voltage or other hazards. Contact your local Neets reseller or distributor.
- If the equipment has slots or holes in the enclosure, these are provided to prevent overheating of sensitive components inside. These openings must never be blocked by other objects.
- Do not use this equipment near water.
- To reduce the risk of fire or electric shock, do not expose this apparatus to rain or moisture and objects filled with liquids.
- Unplug the product before cleaning. Clean only with a dry cloth and not cleaning fluid or aerosols. Such products could enter the unit and cause damage, fire, or electric shock. Some substances may also mar the finish of the product.

FCC Class A Notice:

This equipment has been tested and found to comply with the limits for a Class A digital device, pursuant to part 15 of the FCC Rules. Operation is subject to the following two conditions:

1. This device may not cause harmful interference.
2. This device must accept any interference received, including interference that may cause undesired operation. The Class A limits are designed to provide reasonable protection against harmful interference when the equipment is operated in a commercial environment. This equipment generates, uses, and can radiate radio frequency energy and, if not installed and used in accordance with the instruction manual, may cause harmful interference to radio communications. Operation of this equipment in a residential area is likely to cause harmful interference, in which case the user will be required to correct the interference at his own expense.

FCC regulations state that any unauthorized changes or modifications to this equipment, not expressly approved by the manufacturer, could void the user's authority to operate this equipment.



The lightning bolt triangle is used to alert the user to the presence of uninsulated "dangerous voltages" within the unit's chassis that may be of sufficient magnitude to constitute a risk of electric shock to humans.



The exclamation point triangle is used to alert the user to presence of important operating and service instructions in the literature accompanying the product.

Contents

Foreword	2
Revision list	2
What is in the box?	2
Important Safety Instructions	3
Contents	4
Description	5
Specifications	6
Installation	7
Connection and Controls	8
Front	8
Power/Standby indication LED	8
Back	8
RS-232 connector	9
Switch for selection RS-232 or Auto On/Off mode	9
Balanced audio connector	9
Unbalanced audio	10
Optical input connector	10
DC input connector	10
How to use	11
The mode select switch	11
Auto On/Off mode	11
RS-232 mode	11
Wake-on-signal technology	12
Equalizer presets	12
Troubleshooting	13
RS-232 protocol	13
Command structure	13
Commands or queries to the Sound Bar	14
Replies from the Sound Bar	14
Global functions	15
Audio input settings	15
Audio output settings	16

Description

The Neets Sound Bar - SB1 is a stylish sound bar, designed to bring the presenter's message to life.

It is designed to give a great sound quality no matter if it is used in a conference call or presenting in a small- to medium-sized meeting room.

The Neets Sound Bar - SB1 is simple and advanced at the same time. It can simply be connected to the display and use the wake-on-signal feature or it can integrate with a control system through the RS-232 port.

Function description

- Control System compatibility
Compatible with all Neets Control Systems
- Can be mounted anywhere or sit on a shelf
Brackets for wall mounting included in the box
- System
2.0 stereo configuration, based on concept from stereo monitors: 2 set of 4" full-tone woofers + 1" tweeter
- Amplifier
Amplifier with built-in DSP functionality
- Power
4 x 20W stereo
- Power on
RS-232 or "Wake-on-signal"
- Cabinet
All MDF construction is covered in black vinyl and the front grill is in fabric
- Power indicator
Power LEDs on the front integrated behind grill

Specifications

Digital Input	Optical TOSLINK female	1
Balanced stereo input	5-pin euro block terminal	1
Unbalanced stereo input	RCA female	2
Auto Power On	Via Auto ON/Off switch on rear	Yes
RS-232	Bidirectional, 3-pin euro block terminal	1
Power input	24 VDC	1
VESA compatible	400 mm and 800 mm	2
Amplifier	Built-in 4x20W	1
Volume	Via connection of control system	Yes
Bluetooth		No
Feedback	Power On indicator on front, integrated behind the grill	Yes

Specifications

Neets Sound Bar SB1

Audio output

Output power	4 x 20 Wrms
THD+N	< 0.1 % @ 1 W
Woofers	2 x 4" dual magnet, sandwich membrane w/rubber surround
Tweeter	2 x 1" soft dome
Frequency Response	50 Hz - 20 kHz +/- 3 dB
Maximum SPL	106 dBA

Unbalanced audio input

Number of inputs	1 x stereo input
Max input level	1 Vrms
Input impedance	< 20 k Ohm
Wake-on-signal	Yes
Connector	2 RCA female

Balanced audio input

Number of inputs	1 x stereo input
Max input level	2 Vrms
Input impedance	< 100 k Ohm
Wake-on-signal	Yes
Connector	1 x 5 pin screw block

Digital audio input

Interface standard	IEC 60958
AC-3, DTS decoding	Not supported
Bit depth	16/24 bit
Sample rate	32/44.1/48/96/192 kHz
Wake-on-signal	Yes
Connector	1 TOSLINK female

Approvals

IEC/EN	61000-6-1
IEC/EN	61000-6-2

RS-232

Ports	1 x bidirectional
Baud rate	19200 bit/sec
Data bits	8
Parity	None
Stop bits	1
Connector	1 x 3 pin screw block

Power input

Input voltage	24 VDC
Max power usage	50 W
Standby power usage	< 0.5 W
Connector	5,5 mm DC plug

Power adaptor

Line voltage	100 VAC – 240 VAC
Line frequency	50 Hz – 60 Hz
Output voltage	24V
Max output current	2.5A
Max power usage	70 Watt

General

Enclosure	Wood (MDF)
Enclosure finish	Mate black vinyl
Front grille	Textile covered MDF
Width	1018 mm / 40.1 inch
Depth	75 mm / 2.95 inch
Depth w. wall bracket	81mm / 3.18 inch
Height	130 mm / 5.1 inch
Weight	4.5 Kg
Shipping width	1120 mm / 44.1 inch
Shipping depth	150 mm / 5.9 Inch
Shipping height	200 mm / 7.8 Inch
Shipping weight	6.5 Kg
Storage temperature	-20 °C to 50 °C
Storage moisture	Non condensing

Installation

Neets Sound Bar - SB1 is designed to be easily installed, in any convenient location. It can be hung on the wall beneath, or above a screen, or placed on a desk free standing.

To use the Sound Bar freestanding on a desk, simply unpack the unit mount the adhesive feet, and it is ready to go.

To use the Sound Bar on a wall use the included brackets, screws and when necessary wall plugs. Unpack the unit, make the measurements on the wall and place the unit on the surface where it should be mounted.



Add the Velcro band to the rear of the PSU as well as in the connection tray, at the rear of the Sound Bar, and place the PSU in the connection tray. As well as connecting the power, it is also recommended to connect the audio cables, before mounting on the wall.



Included in the box is a template for easy mounting. Use a level to ensure the template is horizontally, and then tape the template securely to the wall. Use an awl or other sharp object to punch 4 small holes through 4 of the marked locations on the template.

Remove the template from the wall and drill pilot holes. Pre-drilling is optional, however it will result in a more accurate installation.

Insert and secure the wall anchors.

If drilling into wood stud, do not use the wall anchors.

If drilling into Sheetrock, screw the wall anchors into the drywall with a Phillips head screwdriver until the head is flat against the wall surface. Be careful not to overtighten.

Fasten the Sound Bar brackets to the wall, using the screws supplied in the wall mount kit. Use a level to verify accuracy a final time, and then tighten the screws securely.

Hang the Neets Sound Bar securely on the two (2) brackets.

For mounting the Sound Bar to a cart, use the VESA 400 or 800 holes at the rear of the Sound Bar.

Connection and Controls

Front



Number	Description
1	Power/standby indication led

Power/standby indication LED

The LED indicate the current state of the Sound Bar:

- When powered on the LED will light up
- When Powered off the LED will be off
- When the output is muted by RS-232 command the LED will blink

Back

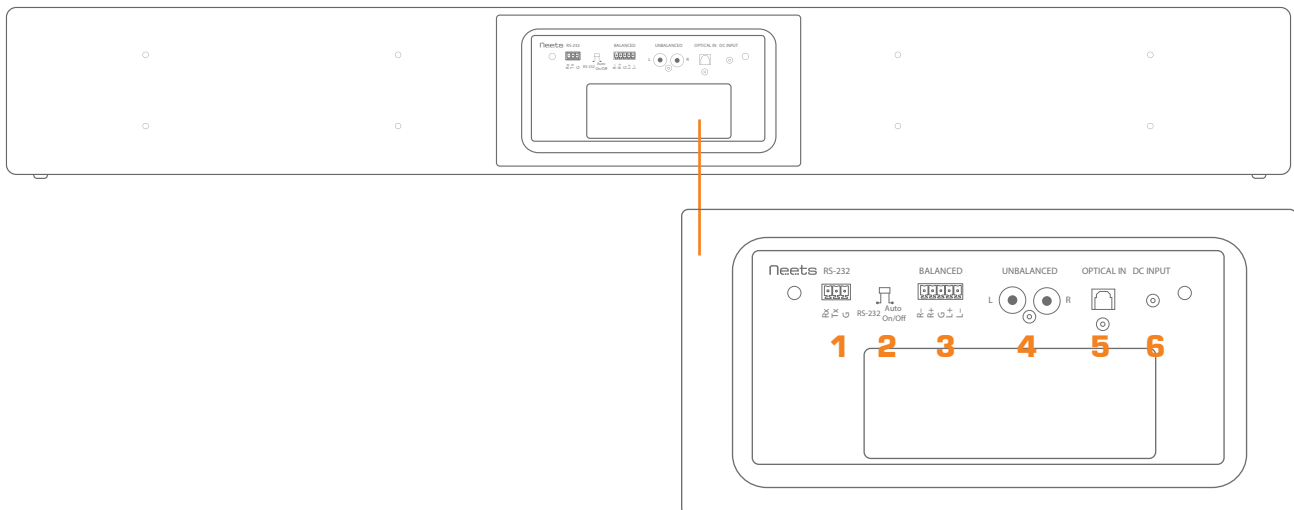

Number	Description
1	RS-232 connector
2	Switch for selecting RS-232 or Auto On/Off mode
3	Balanced audio connector
4	Unbalanced audio
5	Optical input connector
6	DC Input

RS-232 connector

The bi-directional RS-232 connector is used to control the Sound Bar from compatible RS-232 control systems.

To connect the Sound Bar to a control system, connect Sound Bar G to ground on control system. Connect Rx from Sound Bar to transmit/Tx from control system, and Tx from Sound Bar to receive/Rx from control system.

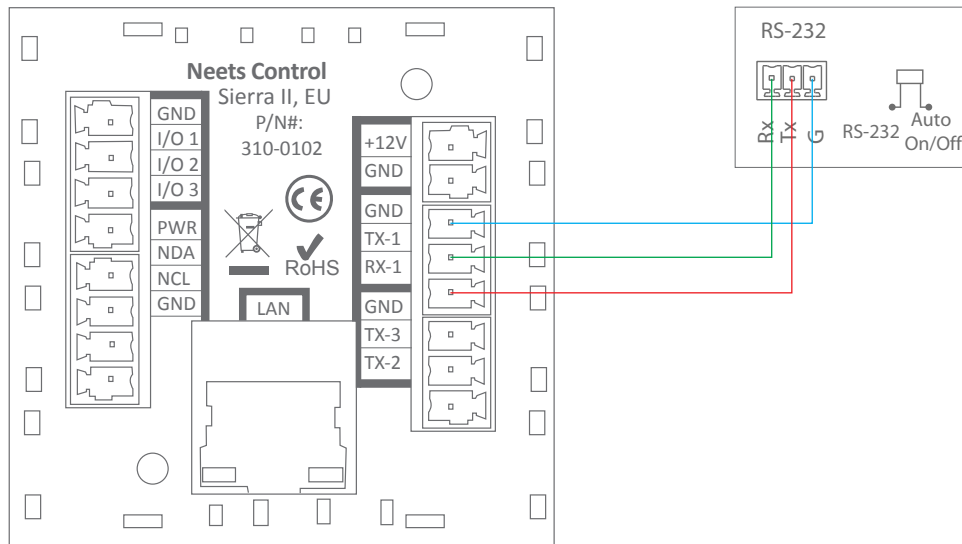
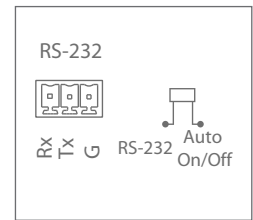

See the section "RS-232 protocol" on page 13 for details of the protocol and remember to set the mode selection switch as described below in "RS-232" mode.

Switch for selecting RS-232 or Auto On/Off mode

This switch is used to select between the two operation modes of the Sound Bar:

For difference in operation modes see chapter "How to use" on page 11.

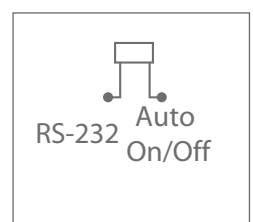

Balanced audio connector

The connector marked "BALANCED" is line level audio input which can be used in both balanced or unbalanced mode. Connect the audio source using the supplied terminal block.

To connect the input to a balanced source connect ground to the shield of both cables.

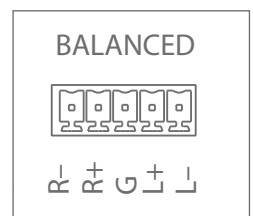

Connect:

- L+ to left positive/hot output
- L- to left negative/cold output
- R+ to right positive/hot output
- R- to right negative/cold output

Depending on which connector is used on the balanced source, use one of the connection diagrams shown below.

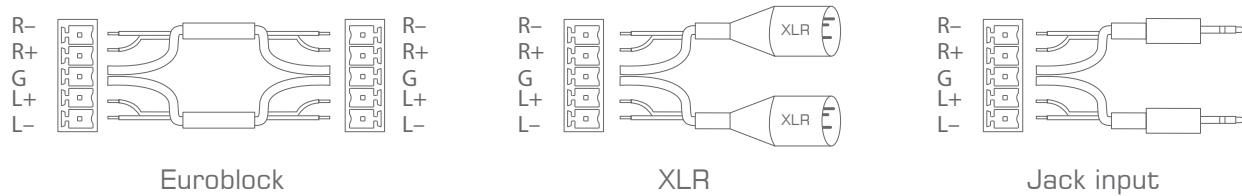

Connect:

- The G to the cable shield.
- L+ to left signal output
- R+ to right signal output
- Finally connect L- and R- to G with a small piece of wire

To connect the input to a single ended/unbalanced source.

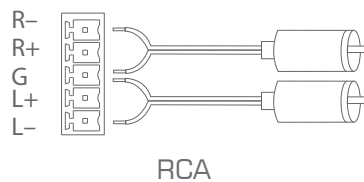

Unbalanced audio

The connector marked “UNBALANCED” is a unbalanced line level audio input. Connect your audio source here with an RCA cable.

White input is left channel, red inputs is right channel.

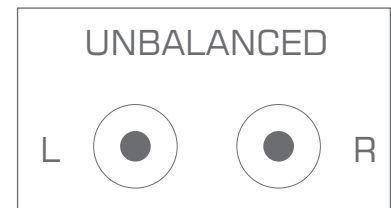

Optical input connector

The connector marked “OPTICAL IN” is SPDIF digital audio input. Connect the digital audio source with an TOSLINK cable.

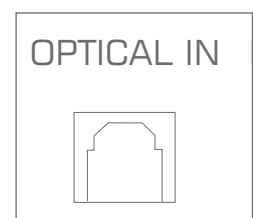

DC input connector

Power is supplied through this connector. Connect the supplied Neets mains power adaptor with the round DC input and connect the mains cable to the AC supply only after all other connections to the Sound Bar have been made. Use only the included Neets mains power adaptor to supply power to the Sound Bar.

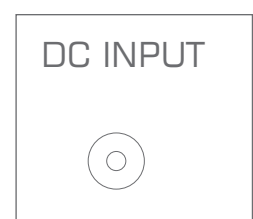

How to use

The mode select switch

The mode selection switch is used to select between RS-232 control mode and Auto On/Off mode.

Auto On/Off mode

When the switch is set in the Auto On/Off mode the Sound Bar will activate the Wake-on-signal function and work autonomously powering on and off as described in "Wake-on-signal" chapter on page 12.

In Auto On/Off mode the RS-232 control port will still be active, but the Sound Bar will not react to incoming commands or queries. Instead, the Sound Bar will reply to a RS-232 command or query telling the connected control system that the Sound Bar is set to Auto On/Off mode.

RS-232 mode

In RS-232 mode, the RS-232 port will be active. The RS-232 port is used to control the Sound Bar by commands and status from Sound Bar can be requested by queries.

The Wake-on-signal function will by default be disabled in RS-232 mode. But by RS-232 command it is possible to activate the function if both Wake-on-signal and RS-232 control is needed for the application.

To control the Sound Bar by RS-232 connect a control system to the RS-232 port with the following settings:

- Baudrate: 19.200
- Databit: 8
- Stopbit: 1
- Parity: None

Please be aware that RS-232 control is deactivated if the Sound Bar is set to Auto On/Off mode. The commands for RS-232 control can be found on page 13.

Wake-on-signal technology

The Sound Bar is equipped with Wake-on-signal technology. This means that the Sound Bar is able to automatically power on and off, if there is a signal present on one of the three connected sources.

When the Sound Bar is powered off the Sound Bar will sense on the audio inputs for one second at a time in a circular manner. means, that the time from activating the source until the Sound Bar powers on can take up to 3 seconds. To power on the Sound Bar simply output a signal on one of the connected sources.

When the Sound Bar have powered on the activating input source will be kept as the active source for as long as there is signal. When the signal is removed the Sound Bar will be kept on for additional 3 minutes before automatically powering off again. And the wake-on-signal function will start over again sensing for an active signal.

The volume level for Wake-on-signal will be last stored volume. That means coming from the factory the Sound Bar will wake up at 0 dB. If another volume level is needed for the specific application the volume should be adjusted by RS-232 command.

To trigger the Sound Bar to wake the BALANCED and UNBALANCED input need to meet the specified level mention in the specification section on page 8. Using the correct audio levels will ensure the best possible user experience of the Sound Bar.

For the optical input an active audio signal shall be present in order for it to be detected as a active source.

Equalizer presets

Three equalizer presets will provide enhanced listening experience for different use scenarios.

	Manual	Device
EQ setting 1	Music - Neutral, default setting	Music
EQ setting 2	Voice - Unified communication setting	Voice
EQ setting 3	Presentation - Video/audio streaming setting	Presentation

The presets can be selected using RS-232 commands.

Troubleshooting

Sound Bar not responding to RS-232 commands

Check your RS-232 cable is connected the right way. Try to swap Rx and Tx.

Sound Bar do not react to the RS-232 commands

Make sure that the "RS-232" mode is selected. See section "The mode select switch" on page 12.

Sound Bar not waking from signal in auto mode

Make sure slide switch on back is in "Auto on/off" position. See section "The mode select switch" on page 12.

Turn up volume on the device signal device.

The sound is too low when using the Sound Bar in "Auto On/Off"

As default, the output level is set to 0dB.

First: Adjust the volume, at connected device, for increasing the output level.

Second: Changing the default volume level: go to RS-232 mode, and adjust level.

The level set in RS-232 mode, is saved and used in "Auto On/Off" mode.

The sound is too high when using the Sound Bar in "Auto On/Off"

As default, the output level is set to 0dB.

First: Adjust the volume, at connected device, for decreasing the output level.

Second: Changing the default volume level: go to RS-232 mode, and adjust level.

The level set in RS-232 mode, is saved and used in "Auto On/Off" mode.

RS-232 protocol

Command structure

The Neets RS-232 protocol is structured in a special way, which is described here. The protocol consist of commands to control the Sound Bar and queries to request status from the Sound Bar.

Both commands and queries is a two way data exchange where the command or query is sent to the Sound Bar. The Sound Bar responds with an acknowledge to a command and a value to a query.

Commands or queries send to the Sound Bar

Commands or queries to the Sound Bar is always structured the same way:

A header: "NEUNIT=1" all commands, queries and replies start with the header

The header and following command is delimited by a comma mark ","

Followed by the command: "POWER=ON"

A command can be changed to a query by replacing the string or number after the equal sign with a question mark "?"

And ending with a carriage return: "\CR"

Carriage return is commonly referred to as "CR". If you need to enter it in hexadecimal, the value is 0D and in decimal, it is 13

Replies from the Sound Bar

The Sound Bar will reply with an acknowledgement to a command to indicate that the command have been accepted

Reply on accepted command: NEUNIT=1,OK\CR

If a query is sent to the Sound Bar the reply will be equal to the query with the question mark replaced by the actual string or value matching the query:

Reply to a query: NEUNIT=1,POWER=ON\CR

If the Sound Bar detects an error in the command or query received, the Sound Bar will reply with the following reply indicating an error:

Reply on errors: NEUNIT=1,ERR\CR

If the Sound Bar is set to Auto On/Off mode by switch on back panel and there is an incoming command, the Sound Bar will reply with the following indicating an error:

Reply when set in Auto On/Off mode: NEUNIT=1,ERR_MODE_SWITCH_IN_AUTO\CR



All RS-232 communications is case sensitive.
It is possible to send multiple commands without time delay between commands by delimiting each command with the command ending \CR.

When adjusting any settings using RS-232 commands the changes will automatically be saved in the Sound Bar. The saved settings will be used as default values next time power is connected to the Sound Bar. This function could be used to change the volume in "Auto On/Off" mode.

Global functions

In the global functions, all the functions allowed to adjust the basic functions of the Sound Bar is shown.

All commands start with "NEUNIT=1," followed by the command in <A>, the value after the equal sign must be replaced with the value in <X> or a question mark, all commands must end with a \ CR

Description	<A>	<X>	Default <X>	R/W
Power amplifier on and off	POWER=<X>	ON or OFF	OFF	R/W
Select audio input	INPUT=<X>	1 to 3	1	R/W
Increment or decrement output volume	VOL=<X>	INC or DEC		R/W
Set output volume to specific value	VOL=<X>	-70 to +12	0	R/W
Mute audio output on or off	MUTE=<X>	ON or OFF	OFF	R/W
Request software version	SWVERSION=?		x.y.z	R

Example of use:

NEUNIT=1,POWER=ON\CR	<- Turn on the Sound Bar.
NEUNIT=1,POWER=OFF\CR	<- Turn off the Sound Bar.
NEUNIT=1,POWER=?\CR	<- Query the power status.
NEUNIT=1,INPUT=1\CR	<- Sets the audio input to input 1 (UNBALANCED).
NEUNIT=1,INPUT=2\CR	<- Sets the audio input to input 2 (OPTICAL).
NEUNIT=1,INPUT=3\CR	<- Sets the audio input to input 3 (BALANCED).
NEUNIT=1,INPUT=?\CR	<- Query the selected audio input.
NEUNIT=1,VOL=INC\CR	<- Increments the master volume one step.
NEUNIT=1,VOL=DEC\CR	<- Decrements the master volume one step.
NEUNIT=1,VOL=DEC\CR	<- Decrements the master volume one step.
NEUNIT=1,VOL=+10\CR	<- Sets the master volume to 10.
NEUNIT=1,VOL=?\CR	<- Query the master volume level.
NEUNIT=1,MUTE=ON\CR	<- Mute audio output.
NEUNIT=1,MUTE=OFF\CR	<- Unmute audio output.
NEUNIT=1,MUTE=?\CR	<- Query the audio output mute state.

Audio input settings

Audio input settings are used to adjust settings for Wake-on-signal settings.

All commands start with: NEUNIT=1,SETTINGS=INPUT, followed by the command in <A>, the value after the equal sign must be replaced with the value in <X> or a question mark, all commands must end with a \CR.

Description	<A>	<X>	Default <X>	R/W
Set wake-on-signal function on or off. This applies for all inputs	WOS=<X>	ON or OFF	OFF	R/W

Example of use:

NEUNIT=1,SETTINGS=INPUT,WOS=ON\CR	<- Set wake-on-signal function on.
NEUNIT=1,SETTINGS=INPUT,WOS=OFF\CR	<- Set wake-on-signal function off.
NEUNIT=1,SETTINGS=INPUT,WOS=?\CR	<- Query the wake-on-signal setting.

Audio output settings

Audio output settings adjust Sound Bar equalizer output parameters.

All commands start with: NEUNIT=1,SETTINGS=OUTPUT, followed by the command in <A>, the value after the equal sign must be replaced with the value in <X> or a question mark, all commands must end with a \CR

Description	<A>	<X>	Default <X>	R/W
Select equalizer preset	EQ=<X>	1 - 3	1	R/W

Example of use:

NEUNIT=1,SETTINGS=OUTPUT,EQ=1\CR	<- Select equalizer preset 1.
NEUNIT=1,SETTINGS=OUTPUT,EQ=2\CR	<- Select equalizer preset 2.
NEUNIT=1,SETTINGS=OUTPUT,EQ=3\CR	<- Select equalizer preset 3.
NEUNIT=1,SETTINGS=OUTPUT,EQ=?\CR	<- Query the equalizer preset.